

Double Oven, 30", 8.2 cu ft, 17 Function, Self-cleaning

Series 9 | Professional

Stainless Steel



Choose maximum capacity, combining two independent ovens so you can cook dishes simultaneously, with touchscreen for ease of use.

- Guided cooking using your touchscreen makes it simple to cook by food, function or recipe.
- 4.1 + 4.1 cu ft total capacity across two oven cavities, with 17 oven functions
- Non-tip, full extension sliding shelves for safe removal of hot dishes
- Accessories include food probe, smokeless grill tray, and more

DIMENSIONS

Height	48 ⁷ / ₁₆ "
Width	29 ²⁹ / ₃₂ "
Depth	23 ²⁹ / ₃₂ "

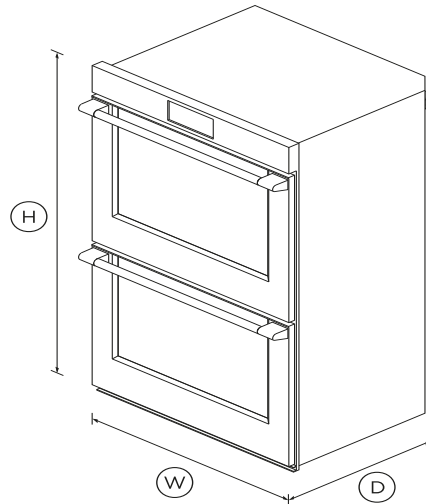

FEATURES & BENEFITS

Cook with confidence

Our touchscreen interface provides an intuitive guided cooking experience that helps deliver perfect results, whether you've been cooking all your life or just starting out. Cook with a favorite method, a hero ingredient, or a go-to cooking function or recipe.

Generous capacity

With an incredible 4.1 cu ft total capacity in each oven, you can

create several perfectly cooked dishes at once using multiple shelves.

Multi-function flexibility

The cooking functions have each been tailored, tested, tweaked and perfected to ensure that no matter what you're cooking, you've got the right heat to match. A food probe precisely monitors cooking in real time, giving you complete control.

Exceptional performance

AeroTech circulates heat evenly for a consistent temperature throughout the cavity, helping you ensure perfect results even when cooking on multiple shelves.

Self-cleaning

<>

Design freedom

Designed to fit seamlessly into your kitchen, this built-in oven features premium materials and elegant styling to support a cohesive, considered kitchen design.

SPECIFICATIONS

Accessories

Broil rack	1
Food probe	1
Full extension sliding shelves	5 sets
Roasting pan	1
Self cleaning side runners	2 sets
Smokeless broil tray	1

Capacity

Shelf positions	8 per oven
Total capacity	4.1 cu ft per oven
Usable capacity	3.6 cu ft per oven

Cleaning

Acid resistant graphite enamel	•
Removable oven door	•
Removable shelf runners	•
Self cleaning side runners	•
Self-clean	Standard and light cycles

Controls

Adjustable audio and display	•
Automatic cooking/minute	•
Automatic pre-set	•
Celsius/Fahrenheit	•
Connected Fisher and Paykel	•
Electronic clock	•
Electronic oven control	•
Food probe	•
Guided cooking by food type	•
Interior light	3 x 20W halogen per oven
Intuitive touchscreen display	•
Multi-language display	UK English, US English,
Precise electronic temperature	•
Sabbath mode with Star K	•

Functions

Aero Bake	•
Aero Broil	•
Air fry	•
Bake	•
Broil	•

Classic bake	•
Dehydrate	•
Maxi Broil	•
Number of functions	17
Pastry Bake	•
Pizza bake	•
Rapid proof	•
Roast	•
Self-clean function	•
Slow cook	•
True Aero	•
Vent bake	•
Warm	•

Performance

AeroTech™ technology	•
Automatic rapid pre-heat	•
Broil power	4400W
Broil width	20"
Number of passes on Maxi	12
Number of passes on broil	10

Power requirements

Amperage	33.2 - 38.3A
Supply voltage	208 - 240V

Product dimensions

Depth	23 ²⁹/₃₂ "
Height	48 ⁷/₁₆ "
Width	29 ²⁹/₃₂ "

Safety

Advanced cooling system	•
Balanced oven door	•
Catalytic venting system	•
Control panel key lock	•
CoolTouch door	•
Full extension sliding shelves	•
Non-tip shelves	•

SKU 81920

TEST The product dimensions and specifications in this page apply to the specific product and model. Under our policy of continuous improvement, these dimensions and specifications may change at any time. You should therefore check with Fisher & Paykel's Customer Care Centre to ensure this page correctly describes the model currently available. ? Fisher & Paykel Appliances Ltd 2020

Other product downloads available at fisherpaykel.com



User Guide



Service & Warranty Booklet



Installation Guide



Resources (zip)



A PEACE OF MIND SALE

24 Hours 7 Days a Week Customer Support

T 1.888.936.7872 **W**www.fisherpaykel.com