

Tape Light Kit Part Number	Description
L-VK1Z1A-16-Temp	1 Zone 1 Area Kit with 16 ft. of Vivid Tape Light
L-VK2Z2A-16-Temp	2 Zone 2 Area Kit with 16 ft. of Vivid Tape Light
L-VK2Z2A-32-Temp	2 Zone 2 Area Kit with 32 ft. of Vivid Tape Light
L-VK3Z3A-49-Temp	3 Zone 3 Area Kit with 49 ft. of Vivid Tape Light
L-VK4Z4A-32-Temp	4 Zone 4 Area Kit with 32 ft. of Vivid Tape Light
L-VK4Z4A-49-Temp	4 Zone 4 Area Kit with 49 ft. of Vivid Tape Light
L-VK4Z4A-65-Temp	4 Zone 4 Area Kit with 65 ft. of Vivid Tape Light
L-RK1Z1A-16-Temp	1 Zone 1 Area Kit with 16 ft. of Radiance Tape Light

Each Kit Includes



Power Supply



Tape Light



Connection Wire



Connectors



Wireless Dimming System

Temp indicates Kelvin Temperature. All LED Tape Light Kits are available in the following Kelvin Temperatures. 2700K (27), 3000K (30), 4000K (40), 5000K (50)

L-VK2Z2A-32-30 (Example part number for 3000K Vivid Series 2 Zones, 2 Areas Tape Light Kit)

Overview of Basic Kit Hookup Diagram

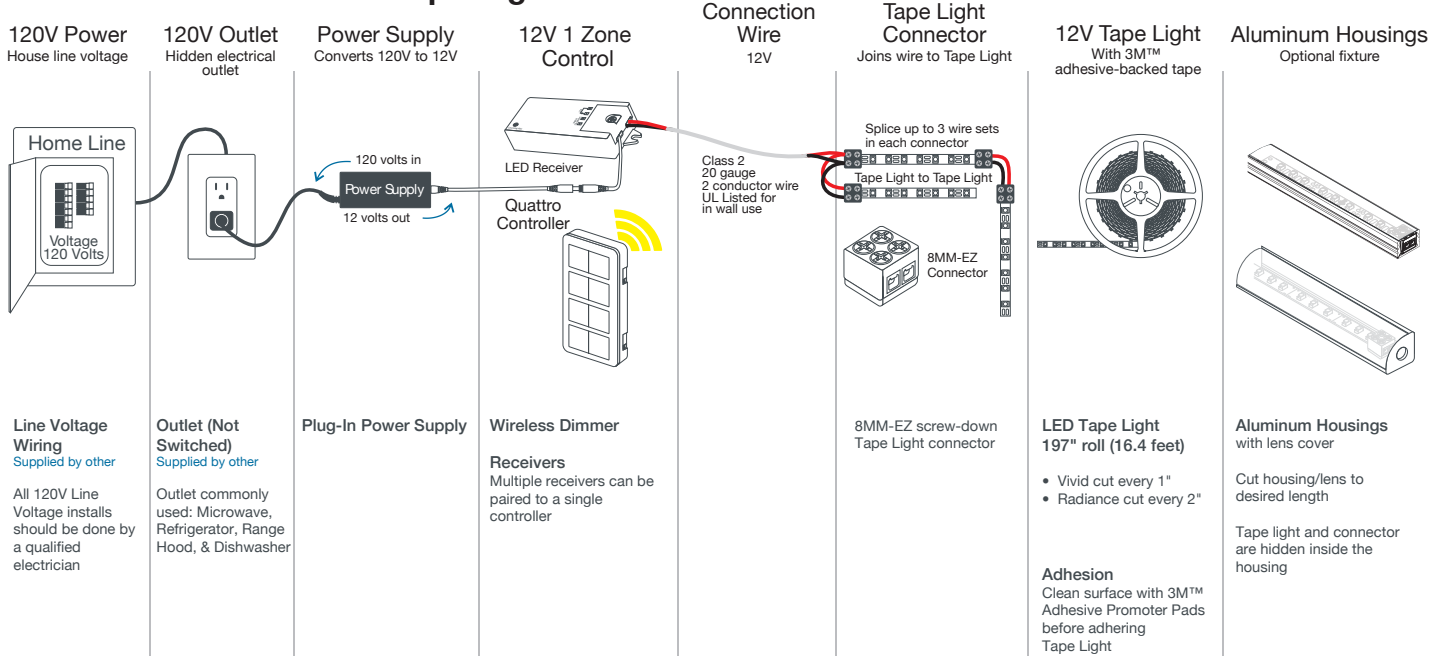

Tools Needed

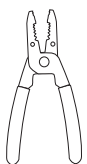

Wire Strippers

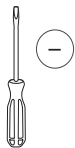

Flat Head Screwdriver

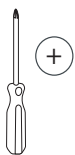

#1 Phillips Screwdriver

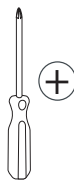

#2 Phillips Screwdriver

Product Legend



Female Barrel Connector T-FBC



EZ Connector L-8MM-EZ



Factory installed Male Plug



Factory installed Female Plug

NOTE

- **DO NOT** connect low-voltage LED tape light to high-voltage power.
- Do not over tighten any screws.
- Maintain polarity on all connections, Red to (+) and Black to (-).
- Maximum 32.8 feet of Tape Light can be connected together.
- For shorter lengths of Tape Light, cut with scissors at cut marks where a black line runs through 2 solder points
– **CUT AT DESIGNATED CUT LINES ONLY**

Pre-Installation Testing

1. Completely unroll the LED Tape Light from the reel.

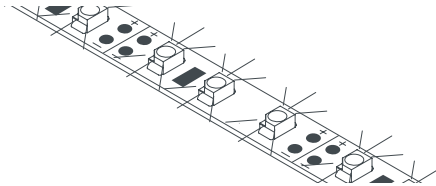
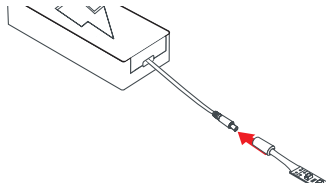

2. **Plug-in Power Supply** – insert the Male Plug on the Power Supply into the Female Connector on the end of the LED Tape Light.

3. Turn on 120V AC power to the Power Supply. All LEDs should illuminate.

Step 1. Wire Plugs to Receiver

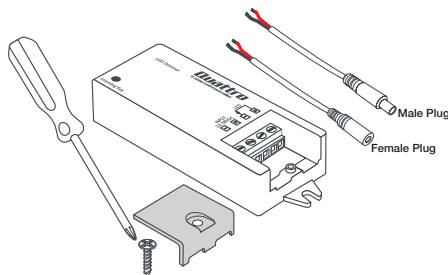

1. Use #2 Phillips to loosen screw and remove cover from Receiver.

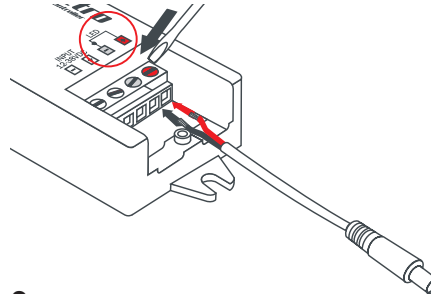

2. Use a flat blade screwdriver to loosen terminals marked LED and insert end of wires for Male Plug. Red wire to (+) and Black wire to (-) terminals. Tighten Screws.

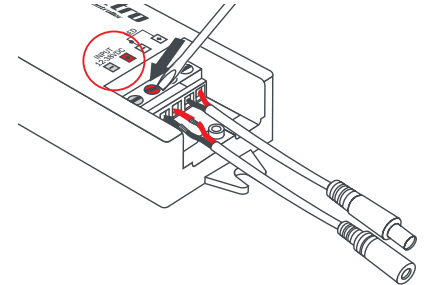

3. Use flat blade screwdriver to loosen terminals marked INPUT and insert end of wires for Female Plug. Red wire to (+) and Black wire to (-) terminals. Tighten Screws.

Provide receptacle for Plug-in Power Supply or use existing outlet behind the microwave, refrigerator, dishwasher, or under the sink. If using our in-line low voltage switches, sensors, or Wireless Control systems, see instructions packaged with the components.

Step 2. Connect Power Supply to Receiver

1. Insert the Male Plug on the Power Supply into the Female Plug on the Receiver.

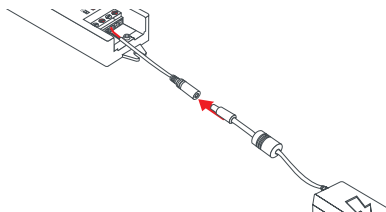

Step 3. Connect Receiver to Tape Lights using Direct or Remote Connection

Direct Connection

1. Insert the Male Plug on the Receiver into the Female Plug on the end of the LED Tape Light.

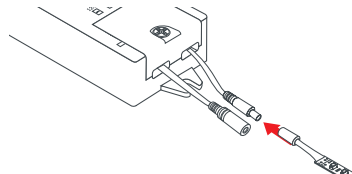

Remote Connection or for field-cut sections of Tape Light

Select between the following options for connecting Receiver to Tape Light

Option 1: Using 8MM-EZ Connector

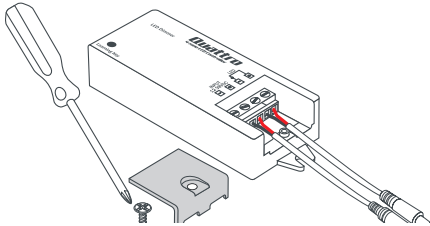

1. Use #2 Phillips to loosen screw and remove cover from Receiver.

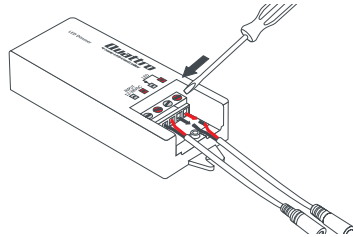

2. Use a flat blade screwdriver to loosen terminals for the Male Plug and remove.

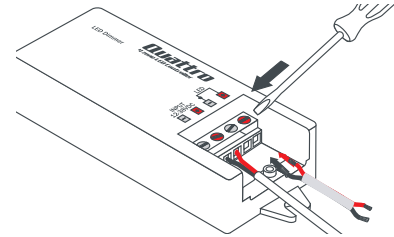

3. Insert one end of stripped wires into Receiver LED terminals, Red wire to (+) and Black wire to (-) terminals. Tighten screws.

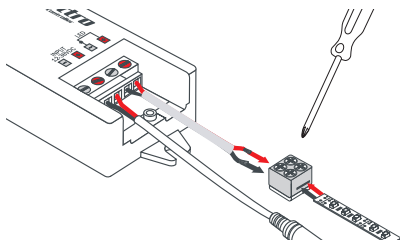

4. Use #1 Phillips to loosen the 4 terminal screws on 8MM-EZ Connector. Peel 1/2" of the adhesive protector from back of LED tape light, insert into connector, evenly tighten screws. Insert wires from Receiver into terminals, Red wire to (+) side of tape, Black wire to (-) side of tape; tighten screws.

Option 2: Using Female Barrel Connector & 8MM-EZ Connector

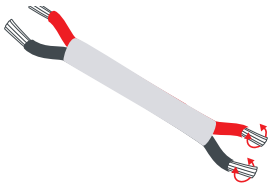

1. Cut a length of connection wire to run from Receiver to Tape Light location. Strip 1/4" insulation from both ends of wire, twist each wire, and fold stripped wires in half on both ends.

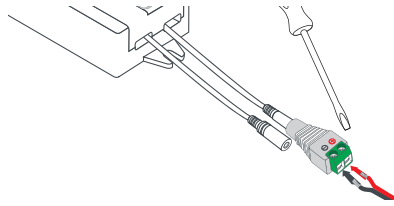

2. Insert Male Plug on Receiver into Female Barrel Connector. Use Flat blade screwdriver to loosen screws on Female Barrel Connector. Insert wires, Red wire to (+), Black wire to (-), and tighten screws.

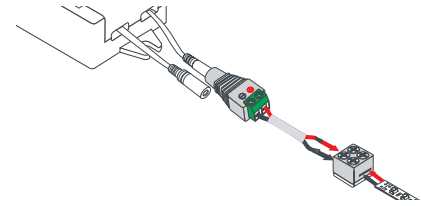

3. Use #1 Phillips to loosen the 4 terminal screws on 8MM-EZ Connector. Peel 1/2" of the adhesive protector from back of LED tape light, insert into connector, evenly tighten screws. Insert wires from Receiver into terminals, Red wire to (+) side of tape, Black wire to (-) side of tape; tighten screws.

Step 4. Mount Tape Light

NOTE

For fuller countertop coverage, install the Tape Light 1-1/2" from the back of the cabinet face frame or light rail.

Direct mounting to surface

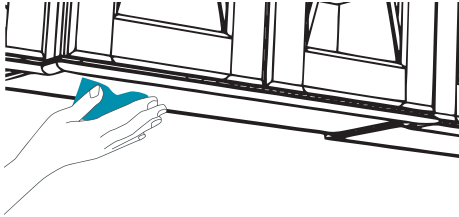

1. Make sure mounting surface is clean, dry, oil-free, and dust-free. Using the Adhesion Promoter Wipes will ensure an extra tight bond to surface.

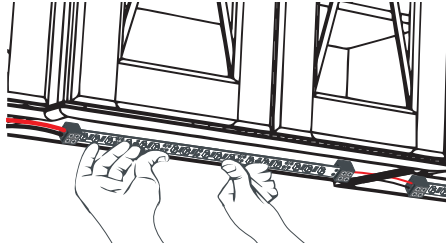

2. Peel the adhesive backing from the Tape Light and mount directly to cleaned surface. Use adhesive pads for securing the connectors to surface.

Using illumLED Aluminum Housings (sold separately)

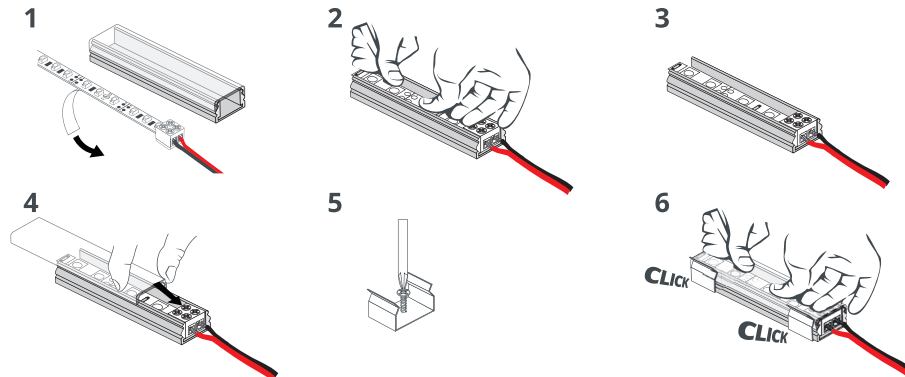

Step 5. Pair Receiver to Wireless Controller

Pairing Instructions

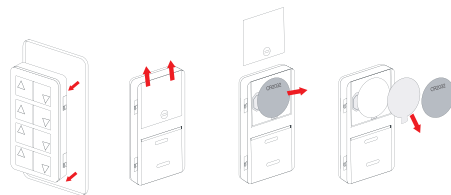

1. Remove Controller from back plate, slide battery compartment open, remove battery, and discard clear plastic tab. Reinsert battery, replace cover.

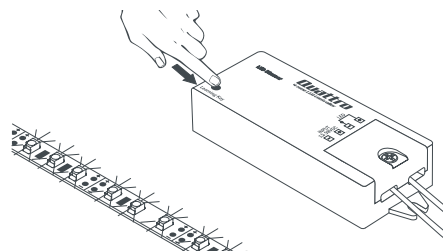

2. Clear the receiver by pressing and holding the Learning button until the lights blink twice

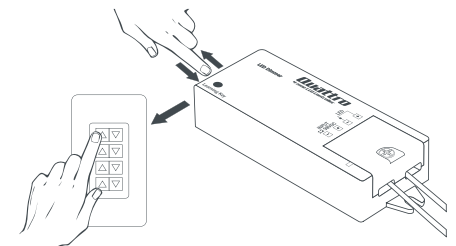

3. Quickly press and release the Learning button and, within 5 seconds, press and release one of the 4-Zone buttons on the Controller. When lights blink once, Controller and Receiver are paired.